

# ***ETERIA***

GPS Tracker

Installation Manual

# TRACKER

GPS Tracker supplied with Eteria platform already contains the SIM card, a backup battery and integrated GSM and GPS antennas. **Device is already active** and can be viewed using the **Eteria App** (see page 6 for instructions on the app)

We recommend using a **double-sided tape** that must be applied as in the photo below in order to **fix the tracker** in the best possible way inside the dashboard (see page 4 for more details).

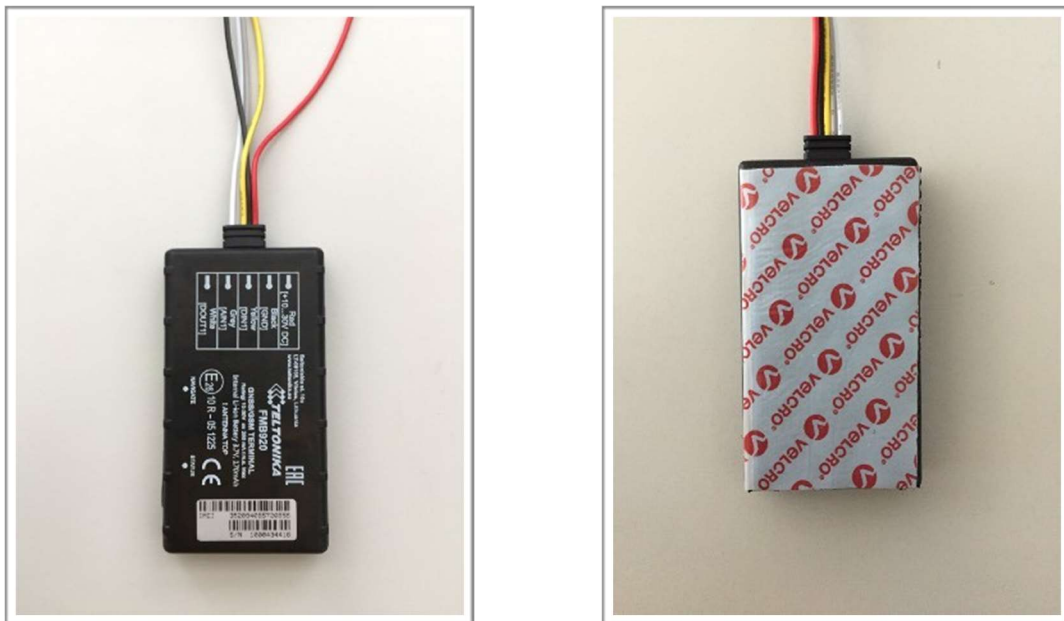

Figure 01. GPS Tracker, connection kit and double-sided tape



**NOTE:** It is not necessary to open the device because both SIM card and battery are **already inserted and ready for use**. In order to use the service it is necessary to access the device (see page 6).

# SERIAL ID

The GPS serial ID is used to **identify the device** using the Eteria platform. Each tracker is **associated on the Cloud** with a vehicle that will report this code. It is possible to identify the GPS serial number using a label placed on the device:



Figure 02. Identification of the tracker's IMEI code



**NOTE:** The IMEI code and the serial code will be used in case of **technical support**.

# 2 STEPS INSTALLATION

To proceed with the installation, simply find a suitable location and connect the tracker to the vehicle battery.

## 1. Gps placement

Finding an ideal location for the device is critical for proper operation. Some general guidelines to follow:

- ▶ It is advisable to install the tracker inside the passenger compartment, in a position far from water, liquids or heat sources. An operating temperature range from  $-10^{\circ}\text{C}$  to  $+50^{\circ}\text{C}$  is guaranteed.



**NOTE:** Installation inside the engine compartment, or in areas of the vehicle not protected from rain or liquids can cause permanent damage to the tracker.

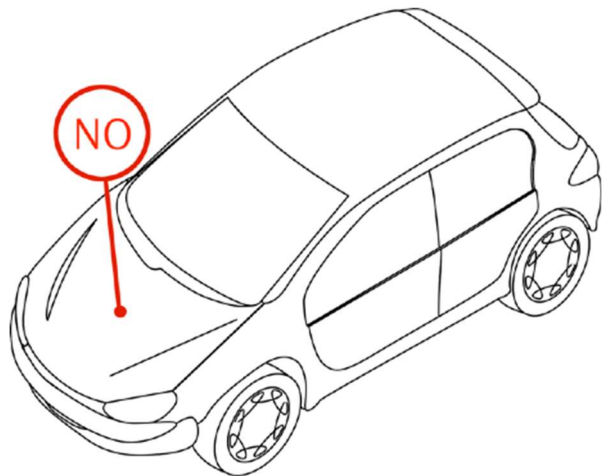
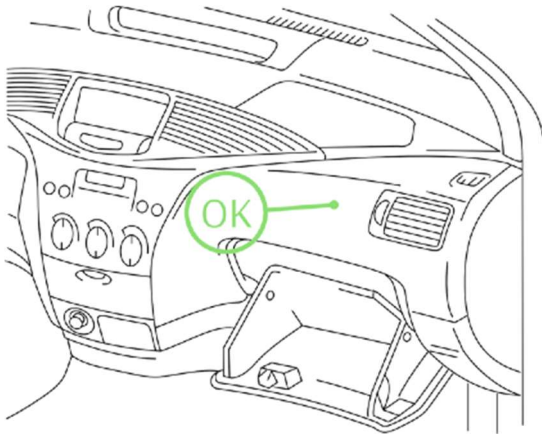

- ▶ GPS tracker should be installed **as far as possible from metal parts** that could shield the GPS signal. On the other hand, the plastic parts are not influential for the GPS signal, so an optimal position is normally inside the dashboard, even if not visible.

- ▶ GPS must be positioned with the **writing facing toward outside of the passenger compartment** (top), so that the integrated GPS antenna on that side is facing in the right direction. It is useful to **fix it to the vehicle using double-sided tape**, so that it correctly detects vibrations.



**NOTE:** *Improper device orientation causes loss of GPS signal resulting in less accurate or missing locations.*

Tracker is equipped with an accelerometer to detect accidents and vehicle towing. It is **useful to fix the device to the vehicle chassis**, so that it does not move autonomously inside the dashboard while the vehicle is being moved.



**NOTE:** *The tracker can be fixed to the frame for example with double-sided tape*

## 2. Power connection

The GPS tracker can work both on vehicles with +12V power supply and heavy vehicles with +24V power supply.

Each connection cable has a unique color.



Figure 03. Connection cables.

<b>PIN 1</b> VCC	RED	<b>Mandatory</b>	Battery positive (+) 12V/24V
<b>PIN 2</b> GND	BLACK	<b>Mandatory</b>	Battery negative (-)
<b>PIN 3</b> ACC	YELLOW	<b>Optional</b>	Ignition input connection
<b>PIN 4</b> AIN 1	GRAY	<b>NO</b>	Not used
<b>PIN 5</b> DOUT 1	WHITE	<b>Optional</b>	Engine stop signal

The tracker basic installation **only involves connection of two (or three) cables:**

1. **PIN 3 ACC** (Yellow cable - optional)

It must be connected to the vehicle's ignition signal, so that this input is powered only when the vehicle's ignition is on. It is essential for the correct detection of vehicle stops and routes.

2. **PIN 2 GND** (Black cable)

It must be connected to the negative pole of the battery. It must be a permanent connection independent of the state of the panel and the ignition of the vehicle.

3. **PIN 1 VCC** (Red cable)

It must be connected directly to the positive pole of the battery at +12V or +24V. It must be a permanent connection independent of the state of the panel and the ignition of the vehicle, so that the locator is powered even when the vehicle is off. The low consumption of the device is not a problem for the vehicle battery even for prolonged stops.



**IMPORTANT:** *The battery negative is often connected to the vehicle chassis. However, it is not recommended to connect PIN 2 (GND) directly to the vehicle chassis and a connection directly to the negative pole of the battery is preferable.*



**NOTE:** *It is very important that GPS unit is powered even with the vehicle stationary and the ignition off, to be able to detect attempts to tow the vehicle or tamper with and cut cables.*

# DEVICE ACTIVATION

## 1. Download the App from the Store

To activate an Eteria device, you need to **download the app directly from the Store** by searching for the word "GPSWOX mobile client".



## 2. Register a new account or do the login

### DO YOU ALREADY HAVE AN ACCOUNT?

If you already have an account, even demo, **you can use the same credentials** to login within the Eteria App.

### DO NOT HAVE AN ACCOUNT?

If you do not have a login account, just send an email to **info@eteria.biz** to request it.

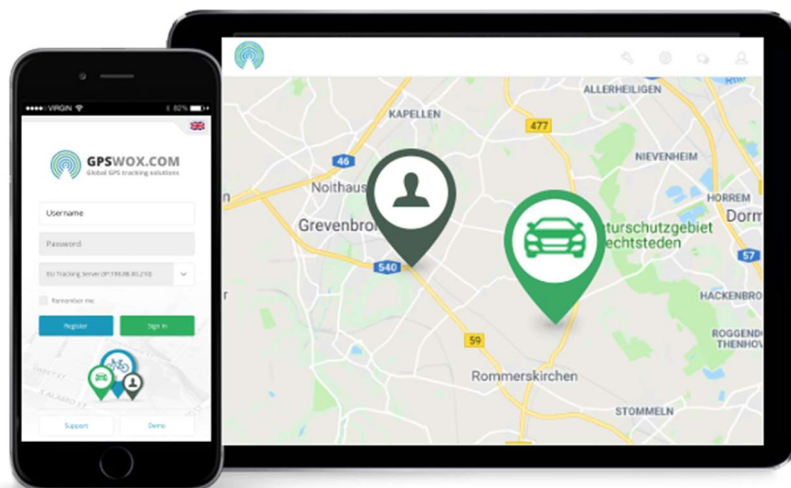

## OPTION: ENGINE STOP

The engine stop option allows you to remotely inhibit the vehicle ignition. It is an optional connection that must normally be performed by skilled personnel.

The engine stop option requires the use of a normal 12V or 24V automotive relay depending on the type of vehicle. Relay can be purchased from any vehicle supply store for a few euros. (For example manufacturer "TE Connectivity" code "1432792-1")

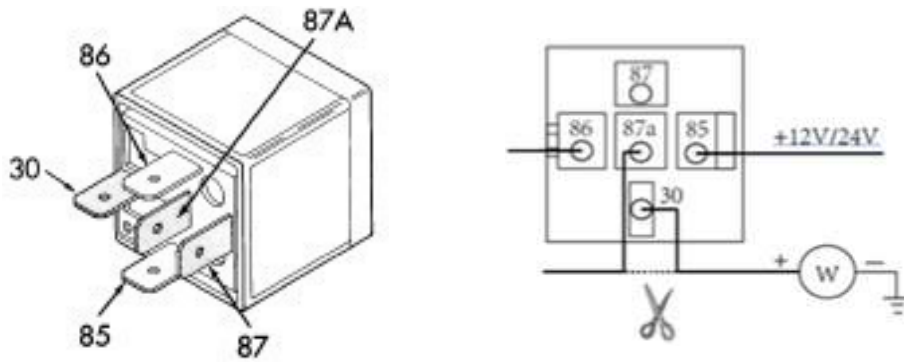

Figure 04. Example of Relay for the engine block

The engine lock relay, which can be controlled from the Cloud using the GPS device, must be connected in order to inhibit the vehicle ignition power circuit.



To install the relay you can follow the connection diagram below:



GPS TRACKER			ENGINE LOCK RELAY	
PIN 5 DOUT 1	WHITE	<-- driving signal -->	86	COMMAND <b>PIN 86</b>
		Battery positive +12V/+24V	85	POWER <b>PIN 85</b>
		Ignition source signal	87a	IGN OUT <b>PIN 87a</b>
		Ignition output signal	30	IGN IN <b>PIN 30</b>

**!** **NOTE:** The engine lock is not a substitute function for locking or locking the vehicle. It must be sent only in exceptional emergency conditions, such as theft, as the vehicle unlocking is sent from the Cloud platform via the GSM network.